

THE EFFECT OF INVESTOR SENTIMENT, INVESTMENT DECISION, AND PROFITABILITY ON STOCK RETURNS THROUGH FIRM VALUE

Andini Nurwulandari, Maison Hamonangan

Faculty of Economics and Business, Universitas Nasional, Indonesia

Email: futuresmart03@gmail.com, andinmanajemen@gmail.com

ABSTRACT

Stock Return is the goal of investors in investing their capital and high company value is the company's goal. This study examines the effect of investor sentiment, investment decisions, and profitability on stock returns with firm value as an intervening variable. The population in this study were 25 public companies indexed on IDX SRI KEHATI in the period May 2018 - May 2023. The type of data is the company's annual panel in the form of volatility from stock price fluctuations. The data collection technique uses purposive sampling and the analysis method used is panel data regression with the Structural Equation Model (SEM) which is processed with STATA 16 software. The sample that meets the criteria is 14 issuers. The results showed empirical evidence (1) Investor sentiment has a negative and significant direct effect on firm value; (2) Investment decisions have a positive and insignificant direct effect on firm value; (3) Profitability has a positive and significant direct effect on firm value; (4) Investor sentiment has a negative and insignificant direct effect on stock returns; (5) Investment decisions have a positive but insignificant direct effect on stock returns; (6) Profitability has a negative and insignificant direct effect on stock returns; (7) Firm value has a negative and insignificant direct effect on stock returns; (8) Investor sentiment has a positive and insignificant indirect effect on stock returns through firm value; (9) Investment decisions have a negative and insignificant indirect effect on stock returns through firm value; (10) Profitability has a negative and insignificant indirect effect on stock returns through firm value. The Intervening test results with the Sobel test show that Firm Value cannot mediathe Investor Sentiment, Investment Decision, and Profitability variables on Stock Returns.

Keywords: Investor Sentiment, Investment Decision, Profitability, Firm Value, Stock Returns

INTRODUCTION

Financial management is concerned with finding ways to create and maintain economic value or wealth. Consequently, all decision making must be focused on wealth creation. Important financial decisions such as introducing new products, when to invest in new assets, when to replace existing assets, when to take out loans from banks, when to issue shares or bonds, when to extend credit to customers, and how much cash to maintain . Financial expert JF Bradley said, "Financial Management is the area of the business, management devoted to a judicious use of capital and a careful selection of sources of capital in order to enable spending units to make in the direction of reaching its goals." Management must be able to use its capital wisely and be able to carefully select existing capital sources to enable the expenditure unit to move towards its goals.

The company's activities are related to its efforts to obtain funding at the minimum possible cost, both related to allocating funds in various forms of investment such as shares, as well as efforts to collect funds to finance investments or spend efficiently. The accuracy of strategic

How to cite:	Nurwulandari, A., & Hamonangan, M. (2024). The Effect of Investor Sentiment, Investment Decision, and Profitability on Stock Returns Through Firm Value. (6)1. <i>Equivalent: Jurnal Ilmiah Sosial Teknik</i> . https://doi.org/10.46799/jequi.v6i1
E-ISSN:	2775-0833
Published by:	Ridwan Institute

financial decision making (or the financial management function) is highly dependent on the accuracy of available accounting data and financial ratios.

Investment in the money market and capital market has become part of the economic fundamentals of a country, not only advanced countries but also developing countries, so appropriate macroeconomic policies will greatly influence the trading process and stock price movements. In countries that adhere to a market economic system, the capital market has become a source of economic progress, because the capital market can be an alternative source of funds for companies (Widiatmojo, 1997).

The money market can be a place where fund owners and fund borrowers meet directly. This meeting usually coincides with short-term transaction offers, for example certificates of deposit, treasury bills, interbank call money, etc. With the existence of a money market, capital owners and capital borrowers are brought together. This is different from the capital market which offers investors investment, especially in the long term, through the instruments and various investment products offered. The capital market is a market where investors who want to invest capital meet and issuers or companies that need funds for business development, for example companies selling shares, the government selling bonds and mutual funds, derivative instruments, etc. The purpose of establishing a capital market is so that a country's system and economy can run well in carrying out its economic and financial functions.

Investment in the capital market has a very important role in achieving profits for a company because the company must look for sources of funds outside the company and will increase economic growth and financial efficiency in a country. Law number 8 of 1998 concerning the capital market which states that the capital market is the activity of trading securities and public offerings of companies. Companies that have gone public must provide financial information to be published so that investors and potential investors can easily choose investments, especially in today's digital era, they can easily buy shares of companies that have gone public on the securities stock market.

The offering or sale of shares of a company for the first time to the public (read: public) on the capital market or stock exchange is called an IPO (Initial Public Offering). So a company that has carried out an IPO is called a public company. The initial offering was carried out after the company received permission from BAPEPAM (Capital Market Supervisory Agency), the company that issues shares which is then called the "Emiten". According to KBBI, an issuer is a business entity (government) that issues valuable paper for sale and purchase. Buyers consisting of the general public, both domestic and foreign, can be referred to as "Investors".

When companies issue shares on the capital market, they are in the form of ordinary shares and preferred shares. The magnitude of the company's value can also be seen from the movement of share prices which are stable and tend to increase in the long term. So, if the higher the share price movement of a company, the higher the value of the company. Shares are one of the securities traded on the capital market. Issuing shares is one of the company's choices when deciding to fund the company.

In 2020, the Central Statistics Agency (BPS) has released the number of public companies listed on the stock exchange market via the Indonesian Stock Exchange (BEI) at 709 (seven hundred and nine) companies as of October 2020. Composite Stock Price Index (IHSG) It can be said to be a lead indicator or an economic reference to see which direction the business is moving in the future and is influenced by global sentiment. Polakitan(2015)says that most share prices of a security tend to increase when the IHSG rises, and vice versa. A stock index is a combination of several individual shares listed in a security that have the same criteria into one group. These criteria can be based on many things, such as industry type, market area boundaries, company size, stock performance level and market capitalization(Cagan, 2017).

Companies that are registered on the IDX are required to report or publish their company financial reports openly every year. IDX has the authority to exclude and/or exclude one or several listed companies from the IHSG calculations. The basic consideration is that if the number of shares of the listed company owned by the public (free float) is relatively small while the market

capitalization is quite large, then changes in the share price of the listed company have the potential to affect the fairness of the JCI movement.

One of the stock indexes on the IDX besides IHSG is "SRI- KEHATI" which was published on June 8 2009, consisting of 25 (twenty five) shares of public companies which are always evaluated twice a year, namely in May and November. This index measures the share price performance of 25 (twenty five) shares of listed public companies that have good performance in encouraging sustainable businesses, have principles and awareness of the environment, social and good corporate governance. The SRI-KEHATI stock index was launched, managed and collaborates with the Indonesian Biodiversity Foundation (KEHATI) which acts as a catalyst to find various more modern and innovative ways to conserve, manage and utilize biodiversity in Indonesia in a sustainable manner.

At the beginning of 2019, the Covid-19 pandemic hit throughout the world and resulted in very worrying changes in various sectors of global society and especially in Indonesia, for example many large companies closed permanently. When we look at it from the investment side, this condition has greatly influenced financial risk because investors experience uncertainty both in terms of economics and individual behavior which can result in a "negative sentiment" regarding the volatility of share prices on global exchanges and the share prices of companies in the world. Indonesia. Ichev & Marin Research(2023), examines the impact of the Ebola epidemic that occurred in 2014-2016, resulting in negative returns on financial markets. In fact, after 2019, one year later what was feared would happen, in Indonesia the Covid-19 pandemic has affected the stock exchange and capital markets in Indonesia and the IHSG experienced a quite significant sharp decline on March 15 2020 and became the lowest point in the four year period. . This happened because of the impact of the detection of the first Covid-19 case in Indonesia in March 2020 which caused negative sentiment towards the JCI.

The initial negative sentiment emerged due to changes in people's behavior caused by the implementation of social distancing by the government, namely Large-Scale Social Restrictions (PSBB), which hampered the overall pace of business movements, not only domestically but also abroad. Business activities and operations are limited, which means a significant reduction in company productivity. The decline in the JCI also adds uncertainty to business and makes investors reluctant to invest capital in companies.

A stock investment product is a piece of paper that states that the owner of the paper is the owner of the company that issued the securities. Tandelilin (2010) defines that shares are proof of ownership of the assets of the company issuing shares. By owning shares in a company, investors will have the right to the company's income and assets, after deducting the payment of all company obligations so that the capital market can be a means for investors to invest in the hope of getting the expected reward (read: return) in the future. as well as low liquidation costs.

The investor's goal in investing their capital is to get a return or return on the funds that have been invested in the company they choose with as little risk as possible. Investors, when deciding on their investment policy on the stock investment products they have chosen, really pay attention to the income they will get in the future, meaning that the availability of funds that are not disturbed for the long term is very suitable for use in buying shares. One form of return on stock investment is "stock returns" in the form of price differences or capital gains(Restiawan & Asytuti, 2020). Stock returns are defined as the results of profits or losses obtained from a stock investment product.

Wahyudi & Pawestri in Fenandar (2019), states that in the "Signaling Theory" investment expenditure provides a signal or signal regarding the company's growth in the future, so that it can increase the share price which is used as an indicator of company value. Company value can be influenced by financial management decisions which include investment decisions, funding decisions or dividend policies and asset management decisions.

Agus Harjito & Martono (2017) also stated, to achieve the company's goals, several main financial decisions are made, including:

(1) Investment decisions, namely how the company obtains investment funds efficiently and the composition of assets that must be maintained and which must be reduced. Investment

decisions involve a long period of time, so the decisions taken must be considered very carefully; (2) Funding decisions or dividend policy, namely policies concerning the decision whether profits earned by the company should be distributed to shareholders or retained to finance future investments (retained profits); (3) Asset management decisions (working capital), namely decisions regarding the allocation of funds or assets, the composition of funding sources that must be maintained and the appropriate use of capital from both inside and outside the company.

Morck (2017) said, in an inefficient market, the variable that also shapes stock market prices is investor sentiment, namely investor confidence in the company's expected cash flows in the future which is not supported by strong fundamental information. Investors can be optimistic or pessimistic. Optimistic investor sentiment will push share prices up and vice versa. This financial behavior can occur and is a pattern of investor behavior such as a person's psychological emotional process that influences the decision to invest. So the behavior of speculating is often associated with the psychological side of investors.

Investor behavior is greatly influenced by the information and data they receive. This shows that individuals receive information and revise beliefs sequentially in a continuous process through receiving information contained in financial reports and also from other information sources such as social media or the internet, and other announcements that can influence investors' investment decisions. The inconsistency of profitability and company value is also an impact of investor sentiment behavior in determining their decisions. The following are several differences in research (research gaps) or gaps in research results, including:

The influence of investor sentiment on company value researched by Julia & Budi (2019) states that investor sentiment does not moderate the influence of profitability on company value. This is contrary to the results of research conducted by Maria (2012) which shows that the negative influence of attachment mechanisms on company value occurs significantly after being moderated by investor sentiment. According to Maria, "there is inefficiency in financial resources because the allocation of funds obtained from debt is not optimal given investor sentiment." Therefore, debt management plays an important role in preventing inefficiencies in financial resources created by investor sentiment to increase company value.

The influence of investment decisions on company value researched by Putu Shiely(2021)shows that investment decisions have no effect on company value. This is contrary to the results of research conducted by Adelia Rantika, Sri Hermningsih and Alfiatul (2020) showing that investment decisions have a positive and significant effect on company value. He said, "The R Square (R²) value of the investment decision variable can explain the company value variable. This means that the greater/higher the value (in percentage) of the investment decision, the greater the value of the company, and achieving the company's goals will only be generated through the company's investment activities with investment decisions."

The effect of profitability on company value was researched by Kusna & Setijani(2018)shows that profitability has a negative effect on company value, this is because "when investors want to invest in a company they are not only fixated on the level of profits generated by the company, sometimes an investor prefers to buy company shares even though the company's profit level has decreased because the company's share price the lower (cheaper)". Contrary to the results of research conducted by Anesty & Laily(2022)which shows that profitability has a positive and significant effect on company value. These results mean that profitability can be a basic consideration for investors before investing.

The influence of investor sentiment on stock returns was researched by Eno Casmi(2019)which states that investor sentiment has no significant effect on stock returns. This is contrary to the results of research conducted by Anissa Putri (2021) which shows that investor sentiment has a positive and significant effect on stock returns, even greater than before the Covid-19 pandemic. Research by Anisa Putri also uses the three factors model developed by Fama-French to increase the accuracy of the model in research. According to Anisa Putri, "investor sentiment during the pandemic has had a positive or unidirectional, significant and greater influence than before the pandemic on stock returns, especially in the Agriculture, Mining, Basic Industry and Chemical, Trade-Services-Investment sectors, as well as the Consumer Goods

Industry. However, this influence is no greater than before the pandemic on stock returns in the Property, Real Estate and Building Construction Sectors. "Infrastructure-Utilities-Transportation Sector, Miscellaneous Industry and Financial Sector, investor sentiment during the pandemic had a positive or unidirectional but not significant influence on stock returns."

The influence of investment decisions on stock returns as researched by Dyah Ayu P (2016) states that investment decisions have a negative and significant effect on stock returns, contrary to the results of research conducted by Verenika Glory, et al (2021) which shows that investor sentiment has a positive and positive effect. significant to stock returns. According to Verenika, "the higher the investment decision, the greater the impact on the share price of LQ45 companies on the IDX." The results of this research are in line with the Signaling Theory concept which states that it is important for companies to provide information to investors, positive information signals will be viewed favorably and the market will tend to be proactive compared to negative information. A good positive signal will be able to attract investors to invest in shares, which will have a positive impact on share prices.

The effect of profitability on stock returns studied by Milka Prasetya (2021) states that profitability has no effect on stock returns, contrary to the results of research conducted by RR Ayu Dika & Gede Mertha (Parwati & Mertha, 2016), which shows the results that partial (overall) profitability has a positive and significant effect on stock returns. According to Ayu Dika & Gede Mertha, with "increasing share prices, the company's share returns will also increase," this theory is supported by signal theory which is a guide for investors to assess the company's prospects. Thus, profitability as a proxy for return on assets (ROA) has a positive and significant effect on stock returns.

Furthermore, in the intervening variable there is an influence of company value on stock returns. It turns out that research researched by Okalesa, et al (2020) shows that company value has a negative and significant effect on stock returns. He believes that "good company value can occur if it has good financial performance because the assessment of a company is reflected in its financial performance which is reflected by the price of the shares owned so that the value of the company increases, the share return also increases." However, the research results are inversely proportional. Contrary to the results of research conducted by Fidhayatin (2012) which shows that company value has a positive and significant effect on stock returns.

The research results above show that there are inconsistencies in research results. So there is a need for further research regarding the influence of the variables above. This research was conducted with the aim of finding out and proving how much "Influence of Investor Sentiment, Investment Decisions and Profitability on Stock Returns through Firm Value in companies listed on IDX SRI-KEHATI in the period May 2018 - May 2023".

RESEARCH METHOD

The quantitative research method used in this research is based on annual panel data sourced from the movement or volatility of stock prices of 14 public companies listed on the IDX SRI-KEHATI stock index during the period May 2018 - May 2023. The data collection technique used is documentation, which includes data from official documents issued by Bank Indonesia, the Central Statistics Agency, data and information on the Indonesian Stock Exchange, market watch, yahoo finance, google finance, stockbit, investing, previous research journals, as well as the issuer's annual financial report which is a source of information.

Quantitative Research Method Steps:

Selection of Data Sources: Identify data sources that are relevant to the research topic, such as stock price movement data, financial reports, and related information from the sources mentioned.

Data Collection: Collect data from selected sources, according to the specified time period.

Data Analysis: Carry out data analysis using descriptive statistical analysis techniques, classical assumption tests, and multiple linear regression analysis to obtain a comprehensive picture of the relationship between research variables.

Data Processing: Data will be processed using statistical software STATA 16.0 for Window, which has the advantage of using syntax type commands and provides ease in interpreting data and a high level of accuracy.

By following the steps above, this research will be able to provide an in-depth understanding of the relationship between research variables and financial report panel data as well as annual published share price movements of 14 public companies listed on IDX SRI-KEHATI during the period May 2018 – May 2023.

RESULTS AND DISCUSSION

A. Classic assumption test

Kuncoro (2018) said that the normality test aims to see whether the data in the study is normally distributed or not. However, the normality test is not a requirement for the Best Linear Unbias Estimator (BLUE). The classical assumption test in this research was carried out so that the panel data regression results used met BLUE, including that there were no symptoms of multicollinearity, heteroscedasticity and autocorrelation.

a. Multicollinearity Test

Multicollinearity is a situation where there is a strong correlation between one independent variable and other independent variables in regression analysis. If multicollinearity is detected in the analysis, the estimated regression coefficient figures obtained have values that are not in accordance with the substance, so that interpretation can be misleading. Apart from that, the standard error value for each regression coefficient can be infinite. Variance Inflation Factor (VIF) is a value that can be used as a reference to check for multicollinearity.

The model is said to be free from multicollinearity if the VIF value < 10 or the tolerance value is getting closer to 1 and the $1/VIF$ value > 10 . Meanwhile, if the VIF value > 10 and $1/VIF < 10$ indicates that an independent variable is multicollinearity (Ghozali, 2013).

c. Heteroscedasticity Test

This test is carried out to find out whether in a regression model there is an inequality of variance from the residuals of one observation to another observation. If the variance from the residual from one observation to another observation is constant then it is called homoscedasticity and if it is different it is called heteroscedasticity. A good regression model is one where heteroscedasticity does not occur. The Breusch-Pagan test was used in this research to carry out heteroscedasticity tests. If the probability value ($\text{prob} > \text{chi}^2$) is greater than the significance level of 0.05, then it is concluded that heteroscedasticity does not occur.

d. Autocorrelation Test

The Run Test was used in this research to carry out the autocorrelation test. If the probability value is > 0.05 significance level, then it is concluded that there is no autocorrelation. However, if the probability value is < 0.05 , then it is concluded that autocorrelation has occurred.

B. Path Diagram Analysis

Path analysis is used to describe and test the relationship model between variables in the form of cause and effect. In this study, path analysis was also used to determine the effect among independent variables and intervening on stock returns. Referring to table 4.6 from thesis (page 70), using standard coefficients, the two regression equations are as follows:

$$FV = 7.44 - 16.88 IS + 0.067 KI + 0.023 Pr$$

$$Rt = 0.01194 - 0.316 IS + 0.00015 ID - 0.0035 FV$$

Research Equation 1:

The coefficients values are used to determine the magnitude and significance of the influence of the variables χ_1 , χ_2 , and χ_3 on Z (NP) and to formulate the regression equation after using the General Least Square (GLS) method.

Analysis:

The constant value (α) has a positive value of 7.44. The positive sign means that it shows a unidirectional influence between the independent variable and the dependent variable. This shows that if all independent variables including IS, ID and Pr, are worth 0 percent or have no change, then the FV is 7.44. The beta values ($\beta_1, 2, 3$) that form the substructure 1 equation are the path coefficients that connect the independent variables to FV (Z). The TV variable has a regression coefficient (β_1) = (-) 16.88, which means that a one percent decrease in TV will result in a decrease of 1688% in firm value. Then the investment decisions increases by one percent will increase the firm value by 6.7%, and if profitability grows by 1 rupiah, the firm value will experience a growth of 2.3%. Assuming all other variables are constant.

Research Equation 2:

The coefficient values are used to determine the magnitude and significance of the influence of the variables χ_1 , χ_2 , χ_3 and Z on Y (Rt) and to formulate the regression equation after using the GLS method.

Analysis:

The constant value (α) has a positive value of 0.1194. The positive sign means that it shows a unidirectional influence between the independent variable and the dependent variable. This shows that if all independent variables including IS, ID, Pr, and FV (Z) are 0 percent or have no change, then the stock returns is 0.1194. The beta values ($\beta_1, 2, 3, 4$) that form the substructure 2 equation are the path coefficients that connect the independent variables and β_4 (Z) to Rt. The TV variable has a regression coefficient (β_1) = (-) 0.316, which means that every one percent decrease in TV, stock returns will decrease by 31.6%. Then the investment decisions increases by one percent, Rt will increase by 0.015% and a decrease of 1 rupiah in profitability will reduce the value of Rt by 0.007%, also a one percent decrease in PBV will result in a decrease in the value of Rt by 0.35%. Assuming all other variables are constant.

Ghozali (2016) explains that the core purpose of the coefficient of determination (goodness of fit R-Square or R²) is to measure how far the model's ability is to explain how the influence of the independent variables together (simultaneously) influences the dependent variable. The coefficient of determination value is between zero and one. A small R² value means that the ability of the independent variables to explain variations in the dependent variable is very limited. An R² value that is close to the total value = 1 (one) means that the independent variables provide almost all the information needed to predict the dependent variable. Based on table 4.6, the path diagram results are as follows:

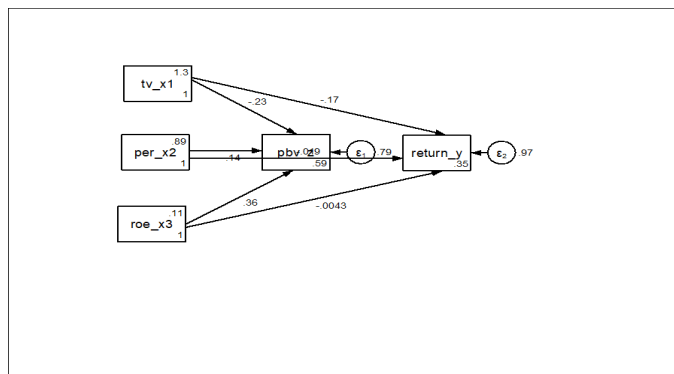

Figure 1. Path Diagram

It is known that the magnitude of the error value for each influence of the independent variable on the dependent variable is:

$$\varepsilon_1 = 0.79 \qquad \varepsilon_2 = 0.97$$

In trimming theory, testing the validity of the research model is observed through calculating the total coefficient of determination (R²):

$$\begin{aligned} &= 1 - (0.79^2) (0.97^2) \\ &= 1 - (0.6241)(0.9409) \\ &= 1 - 0.5872 \\ R^2 &= 0.41 \text{ (41\%)} \end{aligned}$$

The R² value in table 4.6 overall is 0.41 or 41%, which shows that the independent variable is able to explain or predict the variance of the dependent variable and the remaining 59% is explained by error and other variables outside the model.

C. Hypothesis test

Based on the various data and information presented above, the following information on the results of hypothesis testing is obtained:

1. Hypothesis Testing 1

H1: There is a direct effect of investor sentiment on firm value. The test results show that investor sentiment has a negative and significant direct effect on firm value, with a path coefficient value (-) of 16.88 and a p-value = 0.01 < 0.05. So hypothesis 1 is accepted.

2. Hypothesis Testing 2

H2: There is no direct effect of investment decisions on firm value. The test results show that investment decisions have a positive but insignificant direct effect on firm value, with a path coefficient value of 0.07 and a p-value = 0.16 > 0.05. Thus hypothesis 2 is rejected

3. Hypothesis Testing 3

H3: There is a direct effect of profitability on firm value. The test results show that profitability has a positive and significant direct effect on firm value, with a path coefficient value of 0.023 and a p-value = 0.000 < 0.05. So hypothesis 3 is accepted.

4. Hypothesis Testing 4

H4: There is no direct effect of investor sentiment on stock returns. The test results show that investor sentiment has a negative and insignificant direct effect on stock returns, with a path coefficient value (-) of 0.26 and a p-value = 0.13 > 0.05. Thus hypothesis 4 is rejected.

5. Hypothesis Testing 5

H5: There is no direct effect of investment decisions on stock return. The test results show that investment decisions have a positive but insignificant direct effect on stock returns, with a path coefficient value of 0.000088 and a p-value = 0.94 > 0.05. Thus hypothesis 5 is rejected.

6. Hypothesis Testing 6

H6: There is no direct effect of profitability on stock returns. The test results show that profitability has a negative and insignificant direct effect on stock returns, with a path coefficient value (-) of 5.8 and a p-value = 0.97 > 0.05. Thus hypothesis 6 is rejected.

7. Hypothesis Testing 7

H7: There is no direct effect of firm value on stock return. The results show that firm value has a negative and insignificant direct effect on stock returns, with a path coefficient value (-) of 0.003 and a p-value = 0.19 > 0.05. Thus hypothesis 7 is rejected.

8. Hypothesis Testing 8

H8: There is no indirect effect of investor sentiment on stock returns through firm value. The test results show that investor sentiment has a positive and insignificant indirect effect on stock returns through firm value, with a path coefficient value of 0.044 and a p-value = 0.321 > 0.05. Thus hypothesis 8 can be said there is “no mediation”.

9. Hypothesis Testing 9

H9: There is no indirect effect of investment decisions on stock returns through firm value. The test results show that investment decisions have a negative and insignificant indirect effect on stock returns through firm value, with a path coefficient value of (-) 0.00016 and a p-value = 0.42 > 0.05. Thus hypothesis 9 can be said, there is “no mediation”.

10. Hypothesis Testing 10

H10: There is no indirect effect of profitability on stock returns through firm value. The test results show that profitability has a negative and insignificant indirect effect on stock returns through firm value, with a path coefficient value of (-) 0.0007 and a p-value = 0.27 > 0.05. Thus hypothesis 10 can be said, there is “no mediation”.

The following is a summary of the results of the hypothesis testing above:

Table 1. Summary of Hypothesis Testing Results

Hypothesis:	Test result:	Information:
H1: Sentiment investors influential directly negative and significant to company value	The path coefficient value (-) is 16.88 and p value = 0.01 < 0.05	<u>Accepted</u>
H2: Investment decisions have a positive but not significant direct effect on company value	The path coefficient value is 0.07 and the p value = 0.16 > 0.05	Rejected
H3: Profitability has a positive and significant direct effect on value company	The path coefficient value is 0.023 and the p value = 0.000 < 0.05	<u>Accepted</u>
H4: Sentiment investors the direct effect is negative and not significant on stock returns	The path coefficient value is (-) 0.26 and the p value = 0.13 > 0.05	Rejected
H5: Investment decisions have a direct positive but not significant effect on stock returns	The path coefficient value is 0.000088 and p value = 0.94 > 0.05	Rejected
H6: Profitability has a direct negative and insignificant effect on stock returns	The path coefficient value is (-) 5.8 and the p value = 0.97 > 0.05	Rejected
H7: Mark company influential directly negative and not significant to stock returns	Path coefficient value (-) 0.003 and p value = 0.19 > 0.05	Rejected
H8: Investor sentiment has a positive and insignificant indirect effect on stock returns through the firm value	The path coefficient value is 0.044 and the p value = 0.321 > 0.05	No Mediation
H9: Decision investment has a negative but not significant indirect effect on returns shares through firm value	The path coefficient value is (-) 0.00016 and the p value = 0.42 > 0.05	No Mediation
H10: Profitability has a negative but not significant indirect effect on stock returns through firm value	The path coefficient value is (-) 0.00007 and the p value = 0.27 > 0.05	No Mediation

Source: Processed data (2023)

D. Discussion of Research Results

1. The Influence of Investor Sentiment on Firm Value

Based on the results of research that has been conducted, empirical evidence was obtained that investor sentiment has a direct negative and significant effect on company value on IDX SRI KEHATI in the period May 2018 - May 2023. The results of this research are in line with the results of research conducted by Maria. A (2012), long before the pandemic, showed results that the negative influence of embeddedness mechanisms on company value occurred significantly after being moderated by investor sentiment.

During the Covid pandemic, it has now again been proven to have a negative impact on company value, such as a decline in share prices and financial performance,

in this case profit, this is because investors or the market are too sensitive to information/news that is spread so that it can affect company value and investor sentiment. optimistic. In the end, a falling company valuation cannot provide maximum prosperity to shareholders. Liu et al., (2020) said that investor sentiment significantly influence the stock market. When the market is experiencing an uptrend and when there is a slight risk, new investors will behave more positively or optimistically. However, when the market is in a down trend, investor sentiment becomes negative and pessimistic and tends to wait and then open a position in the market.

In the period before and after the pandemic, the tendency of investors to be pessimistic and risk averse or even moderate would of course still consider it very carefully and choose to withdraw their funds from the capital market and then invest their funds in safe haven investment schemes or instruments. has a low level of risk and is safer, for example gold or property. If the investor is a risk taker, perhaps he will maintain his share investment in the capital market or even choose derivative products.

2. The Influence of Investment Decisions on Firm Value

Based on the results of research that has been carried out, empirical evidence was obtained that investment decisions have a direct positive and insignificant effect on company value on IDX SRI KEHATI in the period May 2018 - May 2023. The results of this research are in line with research conducted by Adelia Rantika Sari et al (2020), Hilmy Pradana Sundawan and Prof. Sukirno (2018).

The results of this research reflect that investment decisions are used as an important consideration for investors in investing their capital, one of which is because investment decisions take into account stock market prices where stock market prices are also reflected in the company value. Investment decisions are stated to not significantly affect company value. This shows that the use of company funds in investing has not been able to increase company value to the maximum. An increase in company value occurs if the company experiences an increase in the amount of investment. This increase in the number of investments shows that investor confidence in the company has also increased because it shows the company's growth.

A high PER will be considered by investors as a good signal as "good news" which can accurately indicate the company's value. A high PER indicates that the company's share price is overvalued, but a high PER owned by the company also indicates that the company has the ability to grow better compared to companies with a lower PER.

3. The Effect of Profitability on Firm Value

Based on the results of research that has been conducted, empirical evidence was obtained that profitability has a direct positive and significant effect on the value of the IDX SRI KEHATI company in the period May 2018 - May 2023. The results of this research are in line with research conducted by Amnesty D & Laily N (2022) , Sekar Aditya Dwikirana and Prasetiono (2017).

Brigham & Houston (2010) state that the stock market value can be shown by comparing the market price of a company's shares with its book value. If the market value of a company's shares is greater than its book value, then the company's value can be said to be good because investors are willing to pay for shares greater than its accounting book value. Company value is greatly influenced by the size of the profitability generated by the company. Significant company profitability is the most important indicator for a company and a positive signal for investors, where the higher the ratio, the higher the company's profits and profit growth, so it can be said that the company is "profitable".

4. The Influence of Investor Sentiment on Stock Returns

Based on the results of research that has been conducted, empirical evidence was obtained that investor sentiment has a direct negative and insignificant effect on stock returns. The results of this research are in line with research conducted by William W. Ary (2020), Eno Casmi (2019).

The rise of negative sentiment towards the Indonesian capital market has made many investors reluctant to invest in several companies. For example, negative sentiment occurs due to rising interest rates in the United States, a decline in the dollar exchange rate or inflationary turmoil during the pandemic. This can trigger a decline in share prices resulting in fewer investors from Indonesia than foreign investors. However, there is also a wave of novice investors or newcomers starting to try and enter the stock market. Beginner investors are known to be vulnerable to sentiment-based decisions, especially when they are not supported by strong fundamental information.

Investor sentiment is difficult to measure because it is a fairly abstract concept. Baker & Wurgler (2006) also state that investor sentiment is investors' beliefs about future cash flows and investment risks that are not supported by facts. Investor responses can be positive or negative, depending on the results of the investor's rational or irrational analysis. Investors need to analyze the return and risk of their stock investments. The relationship between return and risk is linear, meaning that the higher the return, the higher the risk faced by investors.

5. The Influence of Investment Decisions on Stock Returns

Based on the results of research that has been conducted, empirical evidence was obtained that investment decisions have a direct positive and insignificant effect on stock returns on IDX SRI KEHATI in the period May 2018 - May 2023. The results of this research are in line with research conducted by Diantia Amendy (2022).

The results of this research have shown that investment decisions and the type of investment used for investment are in line with expectations but are not optimal. Companies that have a high asset growth value indicate that the company has good profit projections in the future period. This is seen by investors as a good opportunity to invest in a company if it has a high total asset growth value, because a high total asset growth value will provide hope of large profits in the future.

Investment decisions are an important factor in the company's financial function, where the value of the company is solely determined by investment decisions, meaning that investment decisions are very important to achieve the company's goals, namely maximizing shareholder prosperity which will only be generated through the company's investment activities.

6. The Effect of Profitability on Stock Returns

Based on the results of research that has been carried out, empirical evidence was obtained that profitability has a direct negative and insignificant effect on Stock Returns on IDX SRI KEHATI in the period May 2018 - May 2023. The results of this research are in line with research conducted by Milka Prasetya (2022), Ni lu Putu Ika and Ni Nyoman Ayu (2016) obtained empirical evidence that profitability as proxied by Return On Equity (ROE) cannot be proven to have an effect or a negative effect on stock returns.

The test results show that profitability has a direct negative and insignificant effect on stock returns, which means that the company does not grow significantly on stock returns. This is because the company's growth opportunities are not only due to increases or decreases in fixed assets but also due to other factors. Apart from that, there is a tendency for investors to prefer to make short-term investments (short term trading), so they pay less attention to the issuer's profitability aspects when buying company shares because they look more at the current market conditions when they want to buy or sell shares.

7. The Influence of Firm Value on Stock Returns

Based on the results of research that has been conducted, empirical evidence was obtained that company value has a direct negative and insignificant effect on stock returns on IDX SRI KEHATI in the period May 2018 - May 2023. The results of this research are close to the results of research conducted by Okalesa et al (2020), which states that company value has a negative but significant influence on stock returns.

This negative and insignificant result indicates that investors' perceptions or views on company value and company performance as reflected in share price fluctuations indicate a poor assessment or response from the market, so it can be said that company shares are less attractive to investors, demand for company shares is not increased significantly followed by a decrease in share prices which affected capital gains as an element of stock returns. The inversely proportional influence of company value on stock returns can also be caused by factors outside the company's internal factors, such as the exchange rate, inflation rate, interest rates and the transition period of the Covid pandemic.

8. Investor Sentiment Indirectly Influences Stock Returns Through Firm Value

Based on the results of the Sobel test, the indirect effect of investor sentiment on stock returns through the firm value of the IDX SRI KEHATI in the period May 2018 - May 2023 can be said not to mediate the influence between investor sentiment and stock returns. So the hypothesis stating that investor sentiment has an indirect effect on stock returns through firm value is not proven.

A decrease in the firm's selling point will affect the stock market because the market response tends to be insignificant. The activity of the company's stock trading volume is actually positive but slowing which in the end can lead to a downward trend in the value of returns, so that it does not motivate investors to open positions and investors do not want to take higher risks so that the issuer's stock returns are not optimal.

9. Investment Decisions Indirectly Influence Stock Returns Through Firm Value

Based on the results of the Sobel test, the indirect effect of investment decisions on stock returns through company value on the IDX SRI KEHATI in the period May 2018 - May 2023 can be said not to mediate the influence between investment decisions and stock returns. So the hypothesis stating that investment decisions have an indirect effect on stock returns through firm value is not proven.

Lack of investor confidence in company performance if it increases, investors or traders will decide not to buy company shares on an ongoing basis. In the end, the declining company value and financial performance will affect the investment decisions that will be taken so that the achievement of the company's goal of increasing the value of stock returns is not optimal.

10. Profitability Indirectly Influences Stock Returns Through Firm Value

Based on the results of the Sobel test, the indirect effect of profitability on stock returns through company value on the IDX SRI KEHATI in the period May 2018 - May 2023 can be said not to mediate the effect between profitability and stock returns. So the hypothesis stating that profitability has an indirect effect on stock returns through firm value is not proven.

Decreased company value and financial performance will affect the company's profitability rate so that the issuer's stock return value is not optimal. Shareholders can measure back with the ROE ratio, the extent to which profits can be generated. When the issuer has a high company value, it will increase the attractiveness of the firm and will indirectly increase the level of return.

CONCLUSION

Referring to the results of the research that has been carried out as well as the discussion of the research results that have been presented and discussed in the previous chapter, several important conclusions that can be drawn are as follows; (1) Investor sentiment directly has a negative and significant influence on the value of the company on IDX SRI KEHATI in the period May 2018 - May 2023. This means that the pessimistic perspective of investors has directly given negative results to the value of TV, resulting in a very significant decline in the value of the company; (2) Direct investment decisions have a positive and insignificant influence on the value of the company at IDX SRI KEHATI in the period May 2018 - May 2023. This means that changes in the PER value have provided positive results on direct investment decisions and have

provided a significant change in the value of the company; (3) Profitability directly has a positive and significant effect on the firm value of the IDX SRI KEHATI in the period May 2018 - May 2023. This means that a change in transactions on the ROE's value has given positive results in increasing the company's profitability directly and provides significant growth in the firm value; (4) Investor sentiment directly has a negative and insignificant effect on stock returns of the IDX SRI KEHATI in the period May 2018 - May 2023. This means that there is a change in the perspective of investors who have given negative results on the value of TV's directly, resulting in a significant decrease in the value of stock returns; (5) Direct investment decisions have a positive and insignificant influence on stock returns on IDX SRI KEHATI in the period May 2018 - May 2023. This means that there is a change in the PER value which has provided positive results on direct investment decisions and provided a significant increase. on the stock return value; (6) Profitability directly has a negative and insignificant effect on stock returns of the IDX SRI KEHATI in the period May 2018 - May 2023. This means that there is a change in transactions on the ROE's value which has given negative results on profitability directly resulting in a significant decrease in the value of stock returns; (7) Firm value directly has a negative and insignificant effect on stock returns of the IDX SRI KEHATI in the period May 2018 - May 2023. This means that there is a change in the PBV's value which has given negative results on the firm value directly resulting in a significant decline in the value of stock returns; (8) Investor sentiment indirectly has a positive and insignificant effect on stock returns through the firm value of the IDX SRI KEHATI in the period May 2018 - May 2023. This means that a change in perspective or an optimistic response from investors has indirectly provided positive results in a little bit significant increase in the value of stock returns through firm value; (9) Investment decisions indirectly have a negative and insignificant effect on stock returns through the firm value of the IDX SRI KEHATI in the period May 2018 - May 2023. This means that there are investment changes that have given negative results on the PER's value indirectly and provide a significant decrease in the value of stock returns through the firm value, and (10) Profitability indirectly has a negative and insignificant effect on stock returns through the firm value of the IDX SRI KEHATI for the period May 2018 - May 2023. This means that a change in ROE transactions has given negative results on profitability indirectly providing a significant decrease in the value of stock returns through firm value.

BIBLIOGRAPHY

- Anesty, D. Y., & Laily, N. (2022). Pengaruh Profitabilitas, Likuiditas, Leverage dan Kebijakan Dividen Terhadap Nilai Perusahaan. *Jurnal Ilmu Dan Riset Manajemen (JIRM)*, 11(5).
- Cagan, M. (2017). *Inspired: How to create tech products customers love*. John Wiley & Sons.
- Casmi, E. N. O. (2019). *Analisis Pengaruh Sentimen Investor Terhadap Return Dan Volatility Di Bursa Efek Indonesia (BEI)*. Universitas Gadjah Mada.
- Chung, S. L., Hung, C. H., & Yeh, C. Y. (2012). When does investor sentiment predict stock returns?. *Journal of Empirical Finance*, 19(2), 217-240.
- Eachempati, P., Srivastava, P. R., Kumar, A., de Prat, J. M., & Delen, D. (2022). Can customer sentiment impact firm value? An integrated text mining approach. *Technological Forecasting and Social Change*, 174, 121265.
- Fernanda, M. (2019). Pengaruh Promosi Penjualan, Daya Tarik Iklan Internet, Dan Kualitas Website Terhadap Pembelian Impulsif. *Jurnal Manajemen Bisnis Dan Kewirausahaan*, 3(5), 7-12.
- Komala, P. S., Endiana, I. D. M., Kumalasari, P. D., & Rahindayati, N. M. (2021). Pengaruh Profitabilitas, Solvabilitas, Likuiditas, Keputusan Investasi Dan Keputusan Pendanaan Terhadap Nilai Perusahaan. *KARMA (Karya Riset Mahasiswa Akuntansi)*, 1(1).
- Kuncoro, M. (2018). *Metode Kuantitatif Teori dan Aplikasi Untuk Bisnis & Ekonomi*.
- Kusna, I., & Setijani, E. (2018). Analisis pengaruh kinerja keuangan, growth opportunity dan ukuran perusahaan terhadap struktur modal dan nilai perusahaan. *Jurnal Manajemen Dan*

- Kewirausahaan*, 6(1), 93–102.
- Parwati, R. R. A. D., & Mertha, G. (2016). *Pengaruh Profitabilitas, Leverage, Likuiditas, dan Penilaian Pasar Saham Terhadap Return Saham pada Perusahaan Manufaktur*, *E-Jurnal Manajemen Unud*, Vol. 5, No. 1. ISSN.
- Peng, C. L., Lai, K. L., Chen, M. L., & Wei, A. P. (2015). Investor sentiment, customer satisfaction and stock returns. *European Journal of Marketing*, 49(5/6), 827-850.
- Polakitan, C. D. (2015). Analisis komparasi risiko saham LQ 45 dan non LQ 45 pada beberapa sub sektor perusahaan yang terdaftar di bursa efek indonesia (BEI). *Jurnal Riset Bisnis Dan Manajemen*, 3.
- Restiawan, S. A., & Asyuti, R. (2020). Evaluasi Faktor Ekonomi Makro Dalam Mempengaruhi Harga Saham. *AKURASI: Jurnal Riset Akuntansi Dan Keuangan*, 2(1), 21–28.
- Tandelilin, E. (2010). Dasar-dasar manajemen investasi. *Manajemen Investasi*, 34.
- Vaurina, E. R. Z., & Hamzah, A. (2023). Pengaruh Kenaikan Pajak Pertambahan Nilai (PPN) 11% Terhadap Indeks Harga Saham Gabungan (IHSG), Harga Saham, Dan Abnormal Return Pada Saham LQ45 Yang Terdaftar Di Bursa Efek Indonesia. *Prosiding Simposium Nasional Perpajakan*, 2(1), 28–45.

Copyright holder:

Andini Nurwulandari, Maison Hamonangan (2024)

First publication right:

Equivalent: Jurnal Ilmiah Sosial Teknik

This article is licensed under the following:

